

Connecting Elements

Die Cast Bracket

Material: diecast aluminum



PG20-20x20

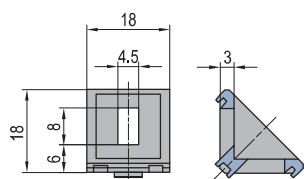

M	Fastening Set	Z	Fastening Set
	M4x8 Bolt zinc plated		M4x8 Bolt zinc plated
	M4 T Nut nickel plated		M4 Pre-set Nut nickel plated

Description	Fastening Set	Mass (g)	Part No.
PG20-20x20 (pcs)		5	3.21.20.2020
PG20-20x20 (set M)	2xM	12	3.21.20.2020.STM
PG20-20x20 (set Z)	2xZ		3.21.20.2020.STZ

Connecting Elements

Die Cast Bracket

Material: diecast aluminum



PG30-30x30

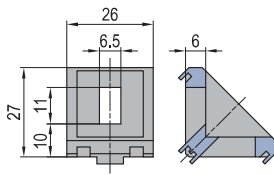

PG30-30x60

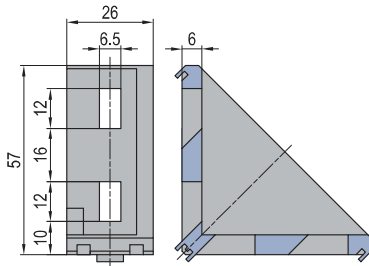

PG30-60x60

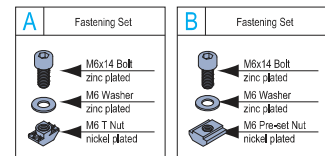
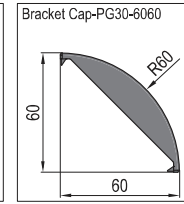
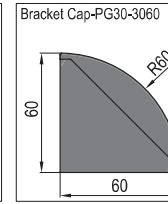
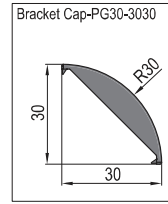
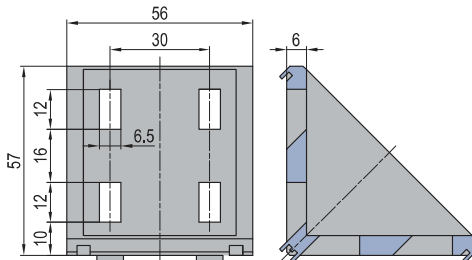

Description	Fastening Set	Mass (g)	Part No.
PG30-30x30 (pcs)		21	3.21.30.3030
PG30-30x30 (set A)	2xA	42	3.21.30.3030.STA
PG30-30x30 (set B)	2xB	48	3.21.30.3030.STB
Bracket Cap-PG30-3030		3	3.22.30.3030
PG30-30x60 (pcs)		53	3.21.30.3060
PG30-30x60 (set A)	4xA	93	3.21.30.3060.STA
PG30-30x60 (set B)	4xB	105	3.21.30.3060.STB
Bracket Cap-PG30-3060		12.4	3.22.30.3060
PG30-60x60 (pcs)		120	3.21.30.6060
PG30-60x60 (set A)	8xA	200	3.21.30.6060.STA
PG30-60x60 (set B)	8xB	224	3.21.30.6060.STB
Bracket Cap-PG30-6060		13.9	3.22.30.6060



Connecting Elements

Die Cast Bracket

Material: diecast aluminum



PG40-40x40

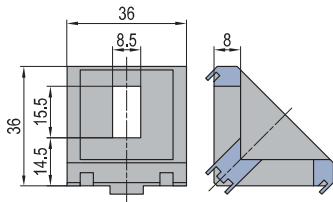

PG40-40x80

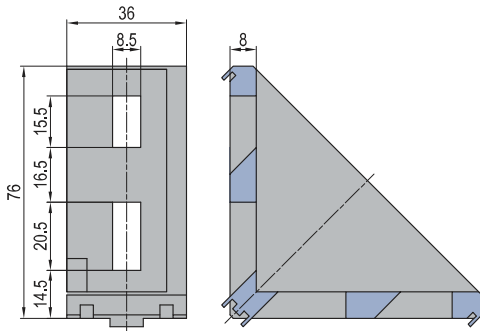

PG40-80x80

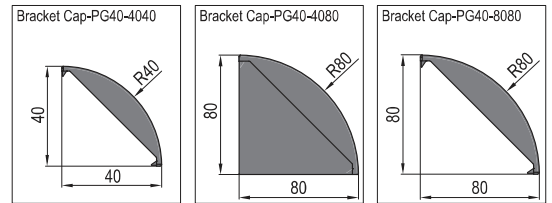
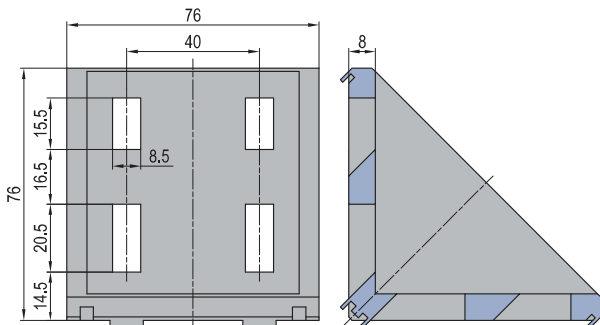

C	Fastening Set	D	Fastening Set	E	Fastening Set	F	Fastening Set	G	Fastening Set
	M8 Flange Nut zinc plated		M8x20 Bolt zinc plated		M8x20 Bolt zinc plated		M8x20 Bolt zinc plated		M8x20 Bolt zinc plated
	M8x20 T Bolt nickel plated		M8 Washer zinc plated		M8 Washer zinc plated		M8 Washer zinc plated		M8 Washer zinc plated
			M8 T Nut nickel plated		M8 Pre-set Nut nickel plated		M8 Spring Washer zinc plated		M8 Pre-set Nut nickel plated

Description	Fastening Set	Mass (g)	Part No.
PG40-40x40 (pcs)		50	3.21.40.4040
PG40-40x40 (set C)	2xC	92	3.21.40.4040.STC
PG40-40x40 (set D)	2xD	92	3.21.40.4040.STD
PG40-40x40 (set E)	2xE	106	3.21.40.4040.STE
Bracket Cap-PG40-4040		6	3.22.40.4040
PG40-40x80 (pcs)		125	3.21.40.4080
PG40-40x80 (set C)	4xC	210	3.21.40.4080.STC
PG40-40x80 (set F)	4xF	220	3.21.40.4080.STF
PG40-40x80 (set G)	4xG	250	3.21.40.4080.STG
Bracket Cap-PG40-4080		22.6	3.22.40.4080
PG40-80x80 (pcs)		260	3.21.40.8080
PG40-80x80 (set C)	8xC	428	3.21.40.8080.STC
PG40-80x80 (set F)	8xF	452	3.21.40.8080.STF
PG40-80x80 (set G)	8xG	508	3.21.40.8080.STG
Bracket Cap-PG40-8080		25.6	3.22.40.8080



Connecting Elements

Die Cast Bracket

Material: diecast aluminum



PG45-45x45

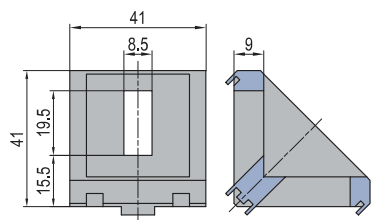

PG45-45x90

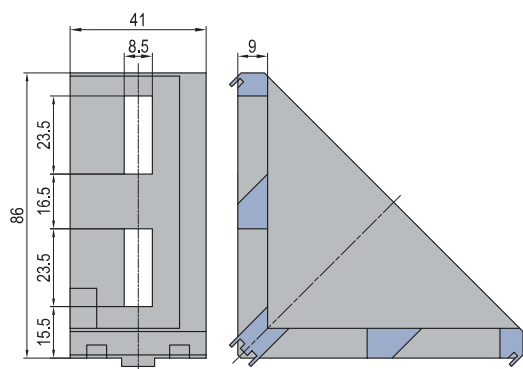

PG45-90x90

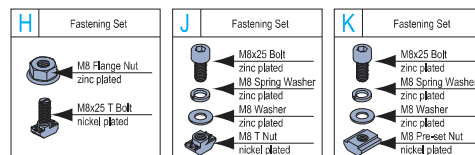
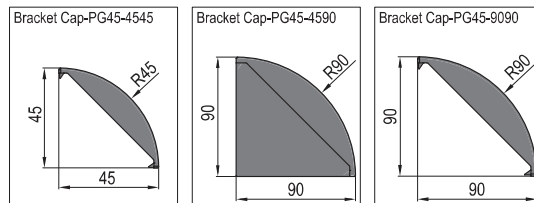
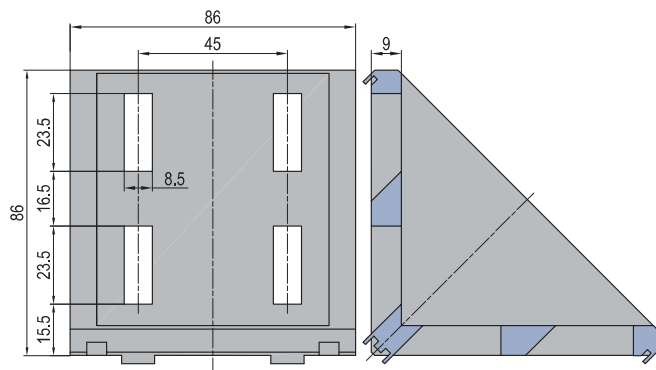

Description	Fastening Set	Mass (g)	Part No.
PG45-45x45 (pcs)		72	3.21.45.4545
PG45-45x45 (set H)	2xH	118	3.21.45.4545.STH
PG45-45x45 (set J)	2xJ	122	3.21.45.4545.STJ
PG45-45x45 (set K)	2xK	134	3.21.45.4545.STK
Bracket Cap-PG45-4545		7.6	3.22.45.4545
PG45-45x90 (pcs)		190	3.21.45.4590
PG45-45x90 (set H)	4xH	282	3.21.45.4590.STH
PG45-45x90 (set J)	4xJ	290	3.21.45.4590.STJ
PG45-45x90 (set K)	4xK	314	3.21.45.4590.STK
Bracket Cap-PG45-4590		28.7	3.22.45.4590
PG45-90x90 (pcs)		390	3.21.45.9090
PG45-90x90 (set H)	8xH	574	3.21.45.9090.STH
PG45-90x90 (set J)	8xJ	590	3.21.45.9090.STJ
PG45-90x90 (set K)	8xK	638	3.21.45.9090.STK
Bracket Cap-PG45-9090		32.5	3.22.45.9090



Modular Assembly System

MAS

Machine Guard System

MGS

Stair and Platform System

SPS

Tubular Framing System

TFS

Connecting Elements

Die Cast Bracket **New!**

Material: diecast aluminum

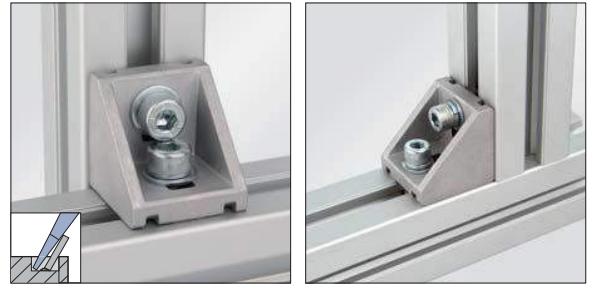

PG50-50x50

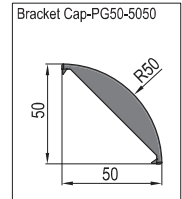
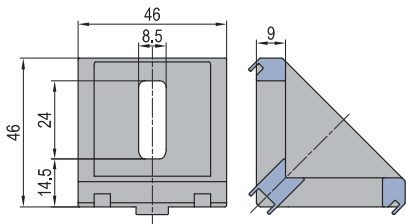

PG50-50x100

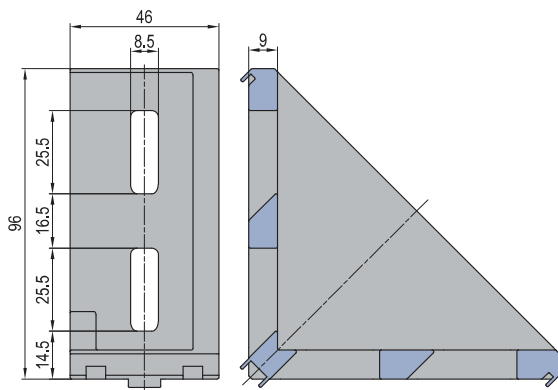

PG50-100x100

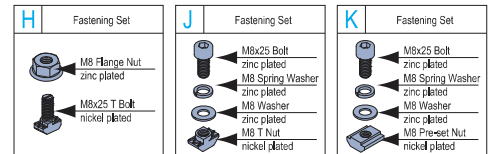
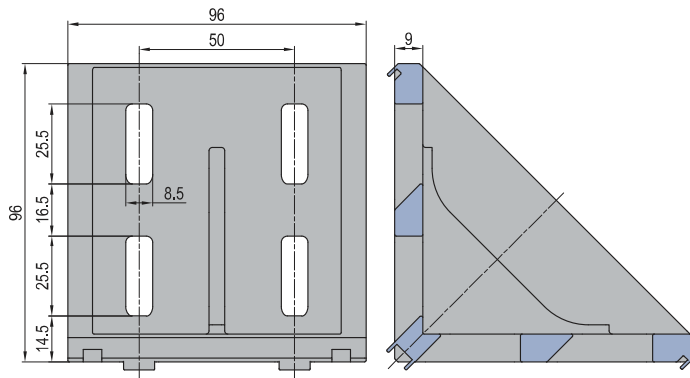

Description	Fastening Set	Mass (g)	Part No.
PG50-50x50 (pcs)		86	3.21.50.5050
PG50-50x50 (set H)	2xH	132	3.21.50.5050.STH
PG50-50x50 (set J)	2xJ	135	3.21.50.5050.STJ
PG50-50x50 (set K)	2xK	152	3.21.50.5050.STK
Bracket Cap-PG50-5050		9.5	3.22.50.5050
PG50-50x100 (pcs)		235	3.21.50.50100
PG50-50x100 (set H)	4xH	327	3.21.50.50100.STH
PG50-50x100 (set J)	4xJ	333	3.21.50.50100.STJ
PG50-50x100 (set K)	4xK	365	3.21.50.50100.STK
PG50-100x100 (pcs)		484	3.21.50.100100
PG50-100x100 (set H)	8xH	668	3.21.50.100100.STH
PG50-100x100 (set J)	8xJ	680	3.21.50.100100.STJ
PG50-100x100 (set K)	8xK	744	3.21.50.100100.STK

